

# EMistyli Surface Texture and Roundness

**Surface Texture Styli:** Highest quality diamond tips in either 60° or 90° configurations. Available Stylus Tip Radii: 2µm, 5µm, 10 µm (**0.3µm** and **0.7µm** tips are available upon request).

**Roundness Styli:** Large palette of styli for all applications. Ball diameters range from 0.3 mm – 10mm (Ruby or Carbide). Special tips available for custom applications.

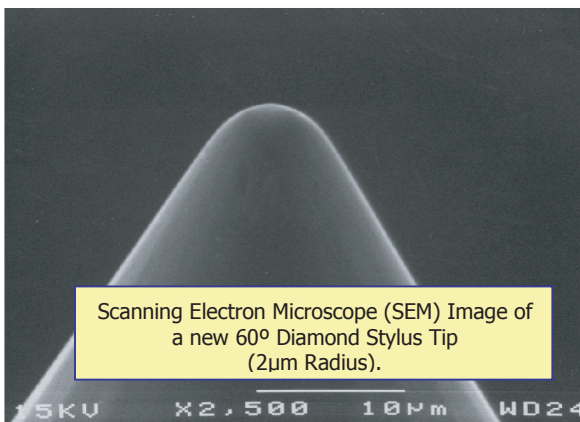
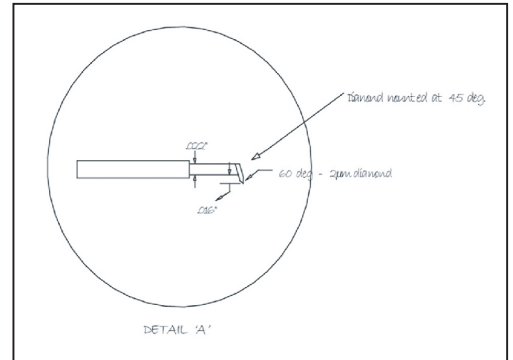

**Stylus Kits**  
**OEM Replacement Styli**  
 Mahr, Mitutoyo, Taylor-Hobson, Zeiss TSK\*

**Standard and Custom Designs**  
**Quality Workmanship**

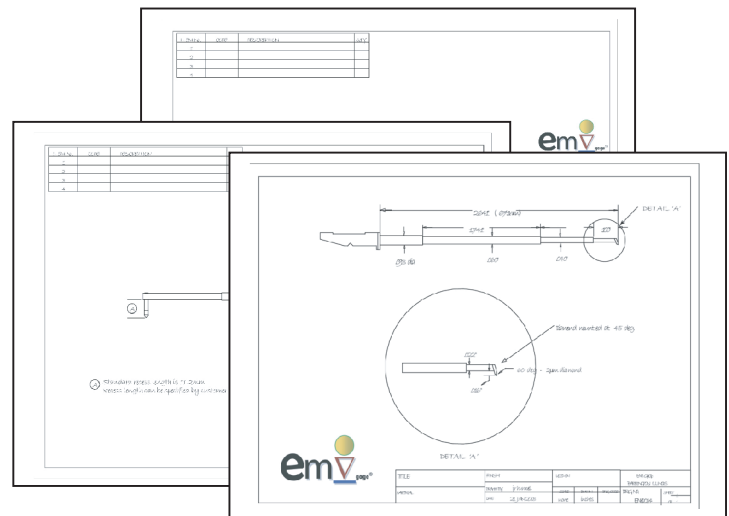

**EMI GAGE**  
 28W144 Industrial Ave Suite # 120  
 Lake Barrington, IL 60010-5939  
 Tel: (847) 277-7511 Fax: (847) 277-7911



EMI GAGE is an independent supplier of support and accessories for surface texture and roundness measuring instruments for use in automotive, aerospace, medical and related industries.  
 \*Not affiliated with OEM manufacturers Mahr, Mitutoyo, Taylor-Hobson, Zeiss TSK\*